

MP 472 Quantum Information Processing

Module objectives

To become familiar with fundamental concepts of quantum information processing and its scientific and technological potentials.

To build up the motivation and ability to follow research and technological developments in quantum information science and technology and to pursue these topics in advanced study or independent research.

Module content

Introduction to classical and quantum information,

quantum communication and cryptography, quantum teleportation,

physical and conceptual models of computation and computational complexity classes,

quantum algorithms,

theory of open quantum systems,

quantum error correction,

fault-tolerant quantum computing, topological quantum computing,

physical realization of quantum information processing.

MP 472 Quantum Information Processing

Learning outcomes

On successful completion of the module, students should be able to:

- Define quantum bits, their composition and elementary quantum operations including measurement;
- Use Schmidt decomposition to characterize entangled and separable two-qubit states and their application in teleportation and dense coding;
- Demonstrate exponential speed-up of quantum computing with the example of the Deutsch-Jozsa quantum computing algorithm;
- Compare computational complexity classes of classical, probabilistic, quantum and non-deterministic computing models;
- Explain the concept of open quantum systems, their states using density matrix formalism and their operations using operator sum representation;
- Present basic single-qubit error processes in the Bloch representation;
- Describe quantum error correction on the example of the Shor nine qubit code in the standard and stabilizer formulations;
- Explain fault-tolerance criteria and topological quantum computation.

MP 472 Quantum Information Processing

Requirements

- 80% Written Exam – duration 90 minutes, answer 2 out of 3 questions
- 20% Continuous assessment (2 quizzes)

Essential information/resources:

- Lectures: 2 hours per week (24 hours of lectures per semester)
- Tutorials: 1 hour per week

<http://www.thphys.nuim.ie/Notes/MP472/>

Additional reading (not required)

- Michael Nielsen, and Isaac Chuang,
Quantum Computation and Quantum Information
Cambridge 2000
- Umesh Vazirani, Michael Crommie, Birgitta Whaley,
Lecture Notes – CS/Physics/Chem 191, UC Berkeley
<http://inst.eecs.berkeley.edu/~cs191/sp05/>
- John Preskill,
Lecture Notes – Physics 219, Caltech
<http://www.theory.caltech.edu/~preskill/ph219/index.html#lecture>
- A. Yu. Kitaev, A.H. Shen, M.N. Vyalyi
Classical and Quantum Computation, AMS 2002

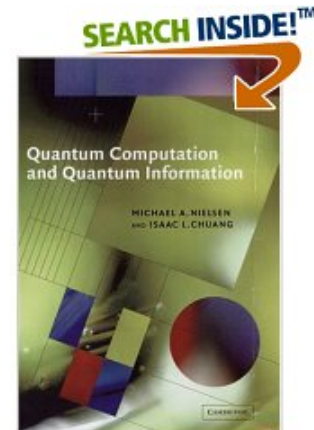

Introduction

Classical information

- classical bit
- Boolean function
- Boolean circuit

Quantum information

- quantum bit(s)
- quantum operations
- quantum state measurement
- quantum circuit
- example: quantum entangler

Examples of quantum information processing

- teleportation

Classical information and its processing

- an elementary unit of (classical) information is classical bit $\mathbb{B} = \{0, 1\}$ whose values, 0 or 1, correspond to two distinct values (states) of an appropriate physical quantity (e.g. electric potential, etc.)
- Boolean function on n variables $F(x_1, \dots, x_n): \mathbb{B}^n \rightarrow \mathbb{B}^k$
- Examples of simple Boolean functions:

negation $\neg x$
(bit flip)

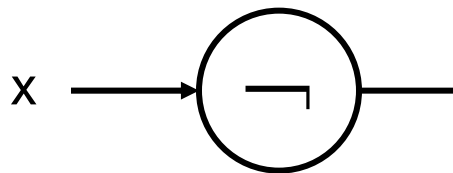

x	$\neg x$
0	1
1	0

(bit flip)

conjunction $x_1 \wedge x_2$

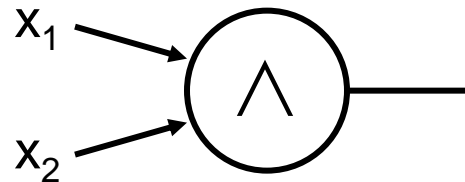

x_1	x_2	$x_1 \wedge x_2$
0	0	0
0	1	0
1	0	0
1	1	1

addition mod(2) $x_1 \oplus x_2$

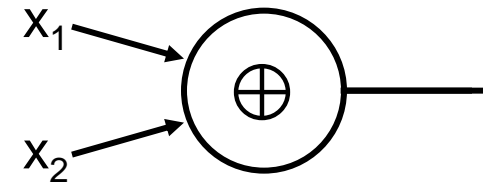

x_1	x_2	$x_1 \oplus x_2$
0	0	0
0	1	1
1	0	1
1	1	0

Classical information and its processing

- a Boolean circuit is a representation of a Boolean function as a composition of other Boolean functions \mathcal{B} (e.g. $\mathcal{B}=\{\wedge, \oplus\}$);
- a circuit over \mathcal{B} is a sequence of assignments involving n input variables $\{x_1, \dots, x_n\}$ and several auxiliary variables $\{y_1, \dots, y_m\}$ where $y_k = f_k(u_1, \dots, u_r)$ and each of the variables u_1, \dots, u_r are either input variables or auxiliary variables preceding y_k ;
- example – addition of two 2-digit numbers (Kitaev et al.)

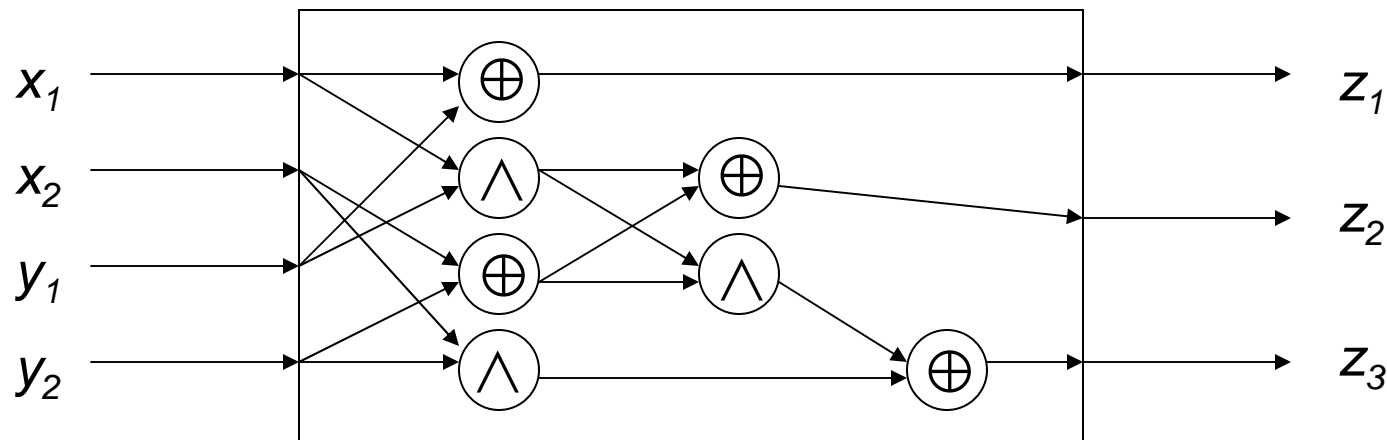

- a basis \mathcal{B} is called complete, if for any Boolean function f , there is a circuit over \mathcal{B} that computes f . Example: $\mathcal{B}=\{\wedge, \oplus\}$.

Quantum information - qubit

An elementary unit of quantum information is quantum bit, qubit, which is physically represented by a quantum two-level system:

a **basis** of a two-level system is formed by two states (vectors)

$\mathcal{B} = \{|0\rangle, |1\rangle\}$ which are **orthonormal**, *i.e.* orthogonal and normalized:

$$\langle i | j \rangle = \delta_{ij} \quad \text{Kronecker delta: } \delta_{ij} = 1 \text{ iff } i=j$$

scalar product

$$\delta_{ij} = 0 \text{ iff } i \neq j$$

Dirac bra-ket notation

$$\text{ket: } |\phi\rangle = c_0|0\rangle + c_1|1\rangle$$

$$\text{bra: } \langle\phi| = c_0^*\langle 0| + c_1^*\langle 1|$$

The qubit can in general be in a **superposition** of **basis states (vectors)** $|0\rangle, |1\rangle$:

$$|\phi\rangle = c_0|0\rangle + c_1|1\rangle$$

$$c_k \in \mathbb{C}, \text{ for } k=0, 1, \text{ s.t. } |c_0|^2 + |c_1|^2 = 1$$

No classical analog !!!

Quantum information - qubit

Quantum states of a qubit form a vector space known as Hilbert space (will be defined rigorously later in the class).

The qubit Hilbert space is two dimensional and is isomorphic to a two-dimensional space of complex numbers

$$|\phi\rangle = c_0|0\rangle + c_1|1\rangle \in \mathcal{H}^2 \simeq \mathbb{C}^2$$

Physical realization of a qubit can *for example* be a spin $\frac{1}{2}$ particle:

$$|0\rangle = |\uparrow\rangle, |1\rangle = |\downarrow\rangle: \quad |\phi\rangle = c_0|\uparrow\rangle + c_1|\downarrow\rangle$$

or two energy levels of an atom or ion,
or opposite superconducting fluxes in a Josephson junction,
or

Quantum logical operations are rotations of a quantum state vector in a Hilbert space, i.e. they are unitary (and **reversible**) operations.

- classical computation processing can be made reversible.

Quantum information - qubits

a quantum state of n qubits is a vector in 2^n -dimensional Hilbert space
(isomorphic to 2^n -dim. space $\underbrace{\mathbb{C}^2 \otimes \mathbb{C}^2 \otimes \dots \otimes \mathbb{C}^2}_{n\text{-times}} = \mathbb{C}^{2^n}$)

Examples of composite quantum states:

a **product state**, e.g.

$$|\psi\rangle = |0\rangle \otimes |0\rangle = |0\rangle|0\rangle = |00\rangle$$

or

$$|\psi\rangle = (c_0|0\rangle + c_1|1\rangle)|0\rangle = c_{00}|00\rangle + c_{01}|10\rangle$$

$$c_{00} = c_0, c_{11} = c_1$$

or an **entangled (strongly correlated) state**, e.g.

$$|\psi\rangle = c_{00}|00\rangle + c_{11}|11\rangle$$

Quantum information **cannot be cloned (copied)**:

assume there is a cloning operator \mathcal{C} s.t.

$$\mathcal{C}|0\rangle = |0\rangle|0\rangle \text{ and } \mathcal{C}|1\rangle = |1\rangle|1\rangle$$

but $\mathcal{C}|\phi\rangle \neq |\phi\rangle|\phi\rangle$ then contradicts the assumption

No classical analog !!!

No classical analog !!!

Examples: single-qubit operations

Phase flip

$$|q\rangle \longrightarrow \boxed{Z} \longrightarrow |\psi\rangle = ?$$

$$|0\rangle \longrightarrow |0\rangle$$

$$|1\rangle \longrightarrow -|1\rangle$$

General state of a qubit:

$$|\phi\rangle = c_0|0\rangle + c_1|1\rangle \longrightarrow \boxed{Z} \longrightarrow |\psi\rangle = c_0|0\rangle - c_1|1\rangle$$

No classical analog !!!

Homework: show that $|\phi\rangle$ and $|\psi\rangle$ are orthogonal if $c_0 = c_1 = 2^{-1/2}$. Why?

Bit flip

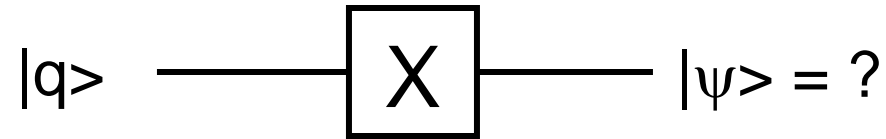

$|0\rangle$ \longrightarrow $|1\rangle$

$|1\rangle$ \longrightarrow $|0\rangle$

General state of a qubit:

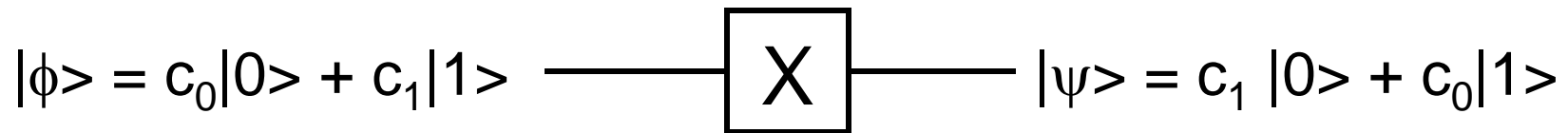

Homework: For what c_0 and c_1 are $|\phi\rangle$ and $|\psi\rangle$ orthogonal?

Hadamard gate

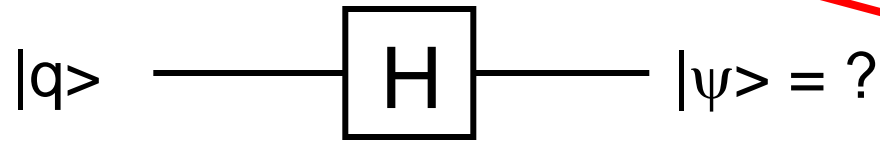

No classical analog !!!

$|0\rangle$ —————→ $2^{-1/2} (|0\rangle + |1\rangle)$

$|1\rangle$ —————→ $2^{-1/2} (|0\rangle - |1\rangle)$

General state of a qubit:

$|\phi\rangle = c_0|0\rangle + c_1|1\rangle$ ——— \boxed{H} ——— $|\psi\rangle =$

$$= 2^{-1/2} (c_0|0\rangle + c_0|1\rangle + c_1|0\rangle - c_1|1\rangle)$$
$$= 2^{-1/2} [(c_0 + c_1) |0\rangle + (c_0 - c_1) |1\rangle]$$

Homework: What $|\psi\rangle$ give these circuits for the input $|\phi\rangle = c_0|0\rangle + c_1|1\rangle$?

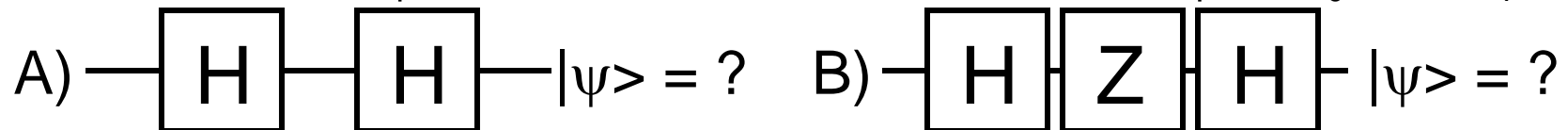

Example of a two-qubit operation: CNOT gate

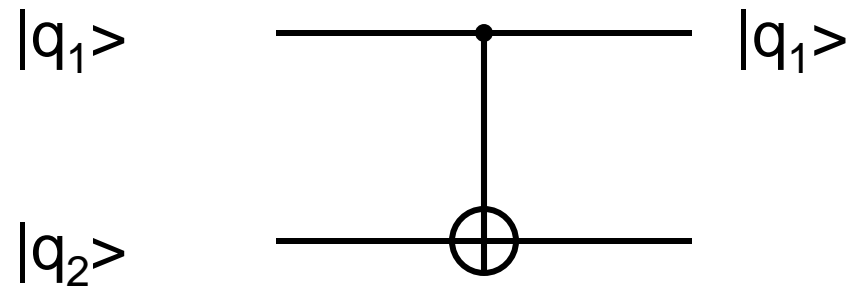

$ q_1 q_2\rangle$	$ 00\rangle$	\longrightarrow	$ 00\rangle$
	$ 01\rangle$	\longrightarrow	$ 01\rangle$
	$ 10\rangle$	\longrightarrow	$ 11\rangle$
	$ 11\rangle$	\longrightarrow	$ 10\rangle$

Note that iff $|q_1\rangle=|1\rangle$, then $|q_2\rangle$ is flipped!!!

Example: a Bell state generator

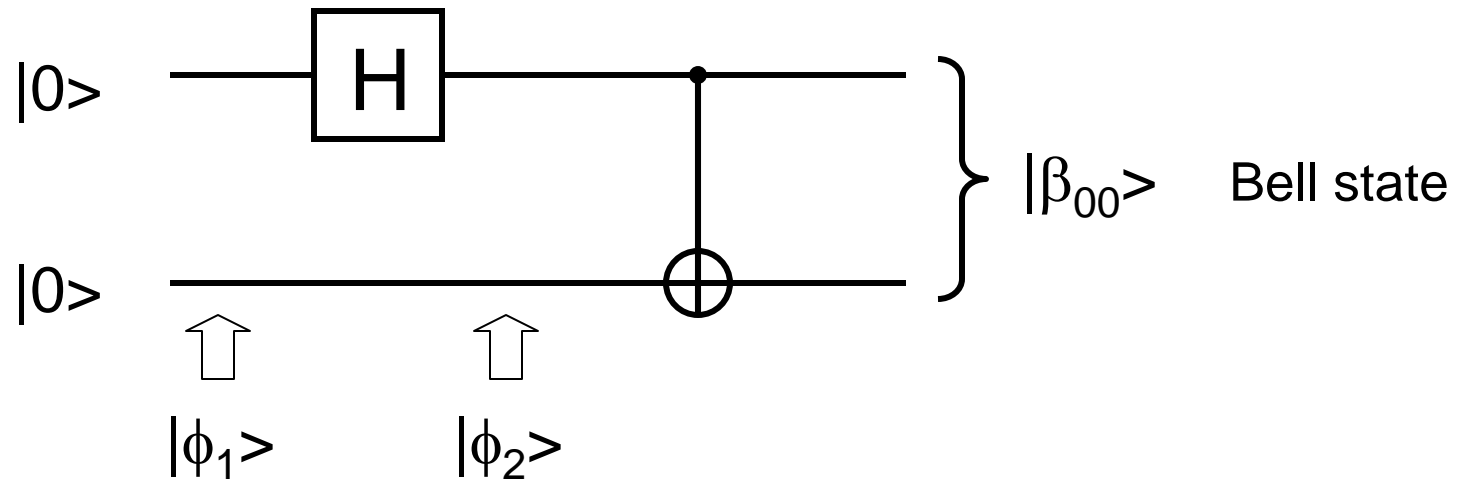

$$|\phi_1\rangle = |0\rangle \otimes |0\rangle = |0\rangle|0\rangle = |00\rangle$$

$$|\phi_2\rangle = 2^{-1/2}(|0\rangle + |1\rangle)|0\rangle = 2^{-1/2}(|00\rangle + |10\rangle)$$

$$|\beta_{00}\rangle = 2^{-1/2}(|00\rangle + |11\rangle)$$

Homework: Construct circuits to generate the other Bell states from $|00\rangle$:

$$|\beta_{01}\rangle = 2^{-1/2}(|00\rangle - |11\rangle)$$

$$|\beta_{10}\rangle = 2^{-1/2}(|01\rangle + |10\rangle)$$

$$|\beta_{11}\rangle = 2^{-1/2}(|01\rangle - |10\rangle)$$

Measurement

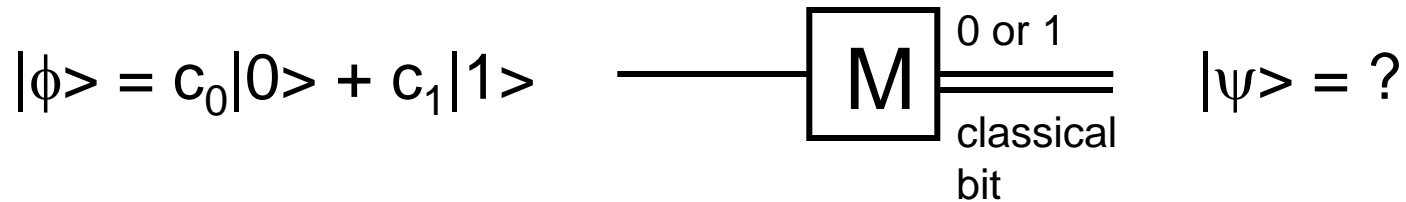

Measurement of one qubit (in the basis $\{|0\rangle, |1\rangle\}$) gives a classical bit of information:

- with a probability $|c_0|^2$, the measurement gives the result $M = 0$; the quantum state after the measurement is **collapsed** to $|\psi\rangle = |0\rangle$;

- with probability $|c_1|^2$, the result is $M = 1$ and $|\psi\rangle = |1\rangle$.

No classical analog !!!

Measurement of an entangled state – EPR paradox

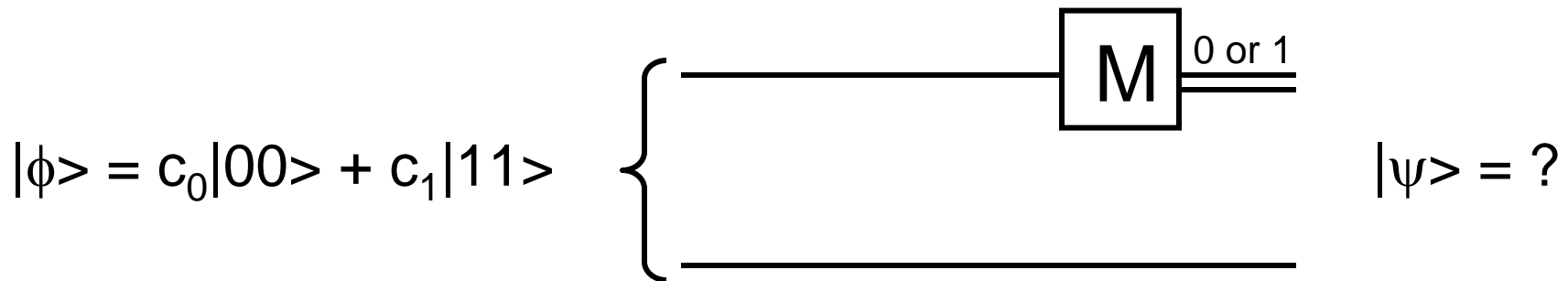

Measurement of qubit 1:

$M = 0$ is measured with probability $|c_0|^2$: $|\psi\rangle = |00\rangle = |0\rangle \otimes |0\rangle$

$M = 1$ is measured with probability $|c_1|^2$: $|\psi\rangle = |11\rangle = |1\rangle \otimes |1\rangle$

if the state of (two) qubits is entangled, measurement of the first qubit completely determines the state of the second qubit after the measurement even if both qubits are spatially separated and cannot communicate (interact)

Einstein, Podolsky, Rosen paradox

No classical analog !!!

No classical analog !!!

TELEPORTATION



Teleportation

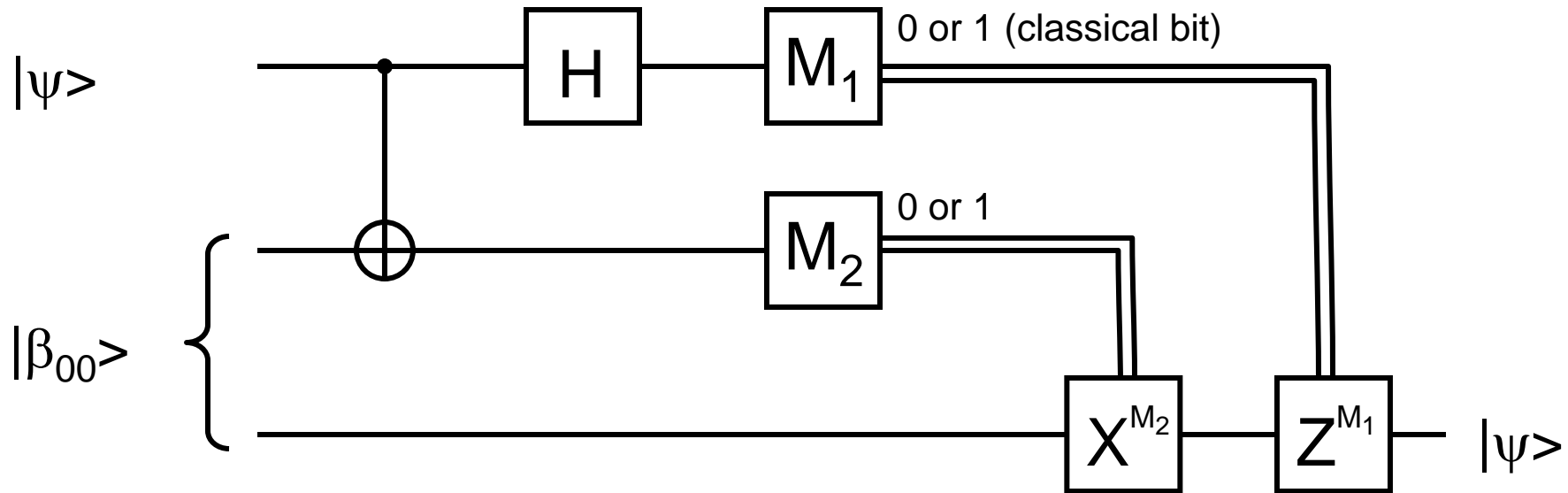

Task:

Teleport an unknown qubit state $|\psi\rangle$ using one Bell state and single qubit and two qubit operations and local measurements.

Teleportation circuit and initial state

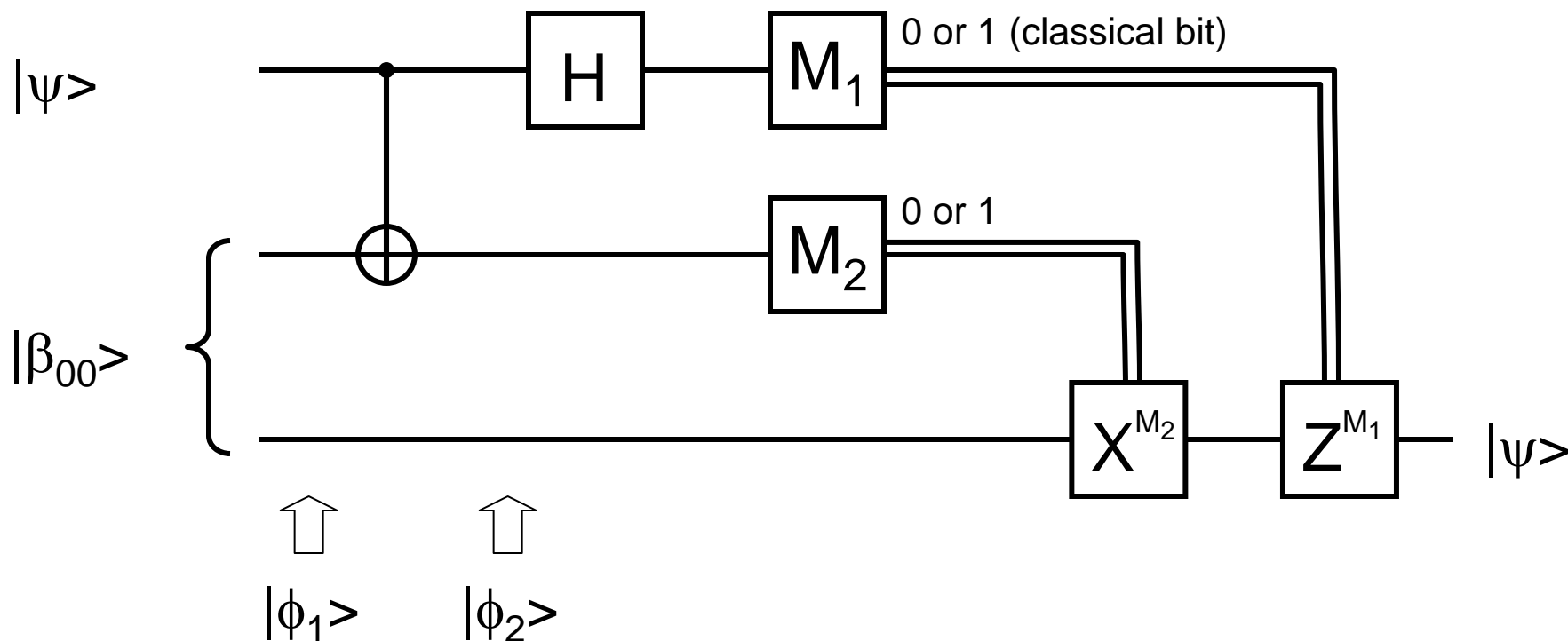

$$|\psi\rangle = c_0|0\rangle + c_1|1\rangle \quad |\beta_{00}\rangle = 2^{-1/2}(|00\rangle + |11\rangle)$$

$$|\phi_1\rangle = |\psi\rangle|\beta_{00}\rangle = 2^{-1/2}(c_0|000\rangle + c_0|011\rangle + c_1|100\rangle + c_1|111\rangle)$$

$$|\phi_2\rangle = 2^{-1/2}(c_0|000\rangle + c_0|011\rangle + c_1|110\rangle + c_1|101\rangle)$$

Teleportation – state before measurement



$$|\phi_2\rangle = 2^{-1/2}(c_0|000\rangle + c_0|011\rangle + c_1|110\rangle + c_1|101\rangle)$$

$$|\phi_3\rangle = 2^{-1} (c_0|000\rangle + c_0|100\rangle + c_0|011\rangle + c_0|111\rangle + c_1|010\rangle - c_1|110\rangle + c_1|001\rangle - c_1|101\rangle)$$

Teleportation - measurement

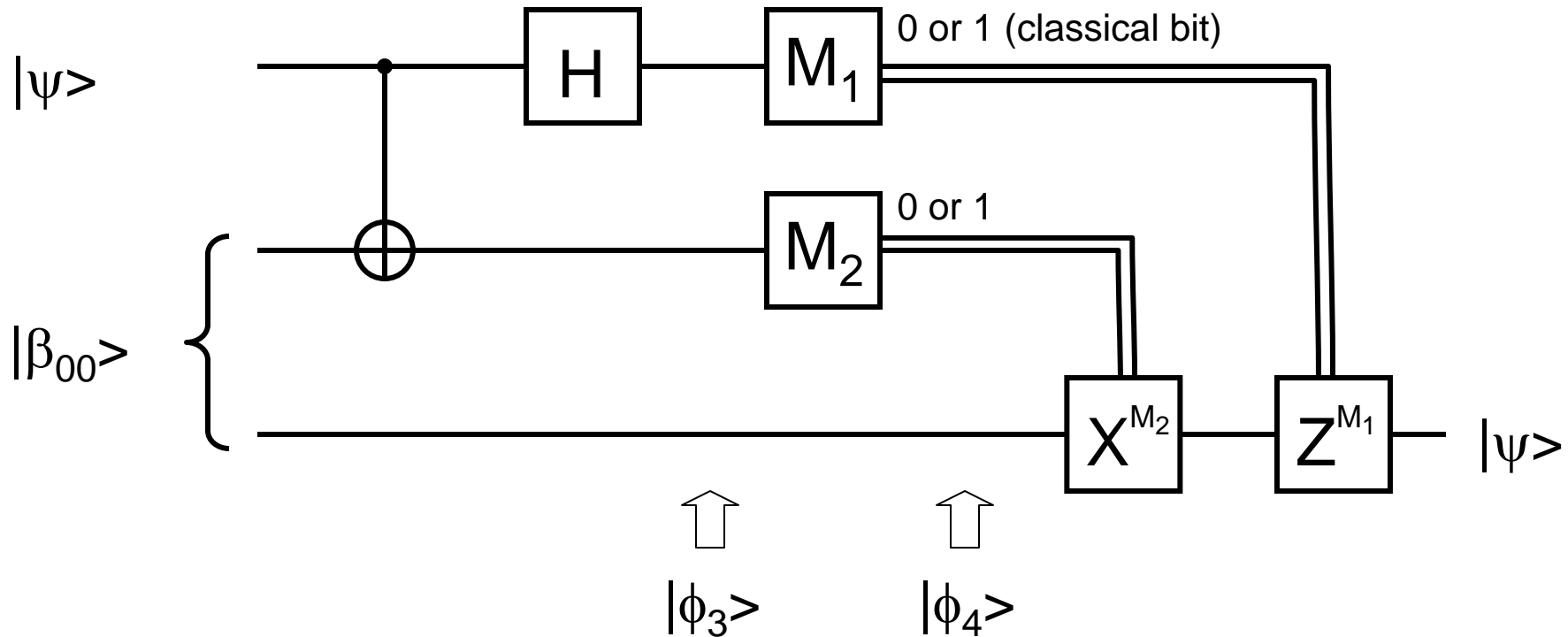

$$|\phi_3\rangle = 2^{-1}(c_0|000\rangle + c_0|100\rangle + c_0|011\rangle + c_0|111\rangle + c_1|010\rangle - c_1|110\rangle + c_1|001\rangle - c_1|101\rangle)$$

Four possible results of the measurements of 1st and 2nd qubit:

$$M_1 = 0, M_2 = 0$$

$$M_1 = 0, M_2 = 1$$

$$M_1 = 1, M_2 = 0$$

$$M_1 = 1, M_2 = 1$$

Teleportation – measurement results $M_1=0, M_2=0$

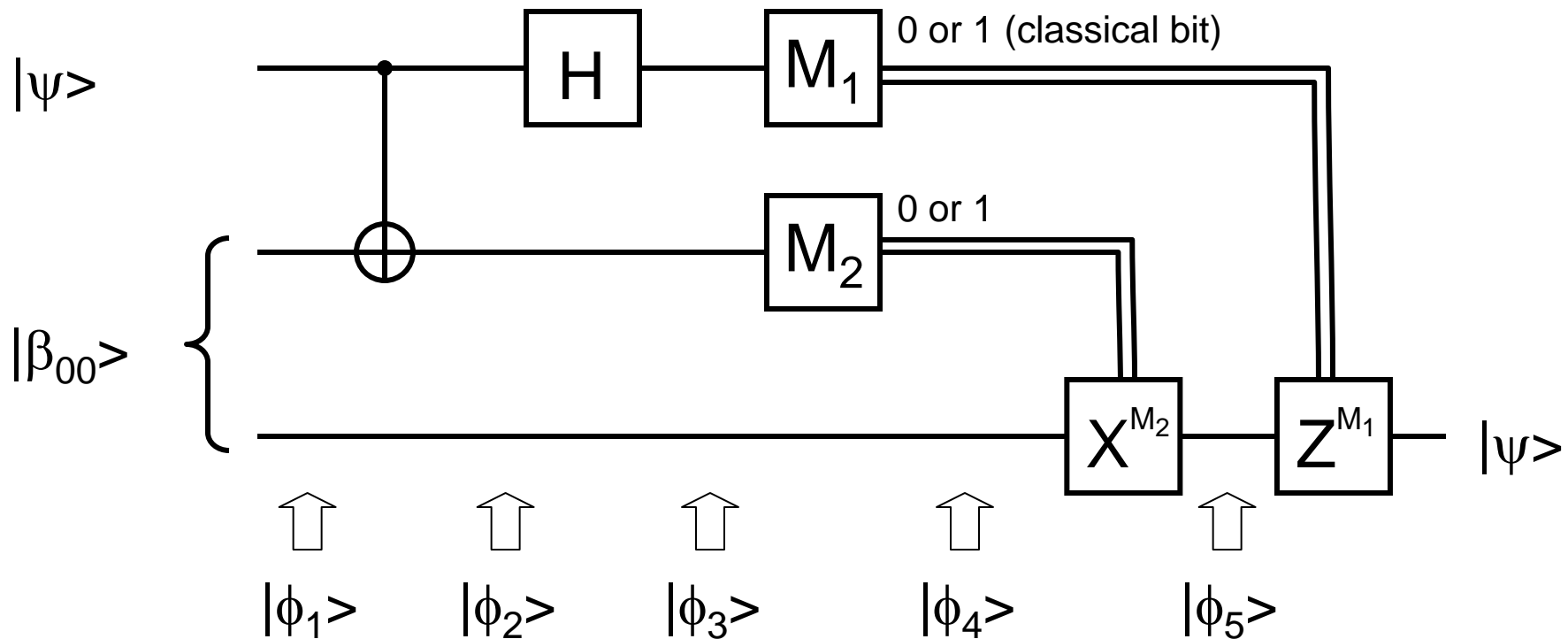

$$|\phi_3\rangle = 2^{-1}(c_0|000\rangle + c_0|100\rangle + c_0|011\rangle + c_0|111\rangle + c_1|010\rangle - c_1|110\rangle + c_1|001\rangle - c_1|101\rangle)$$

$M_1=0, M_2=0$:

$$|\phi_4\rangle = c_0|000\rangle + c_1|001\rangle = |00\rangle(c_0|0\rangle + c_1|1\rangle)$$

$$|\phi_4\rangle \xrightarrow{X^0=1} |\phi_5\rangle = |\phi_4\rangle \xrightarrow{Z^0=1} |\psi\rangle = |\phi_5\rangle = |\phi_4\rangle$$

Teleportation – measurement results $M_1=1, M_2=0$

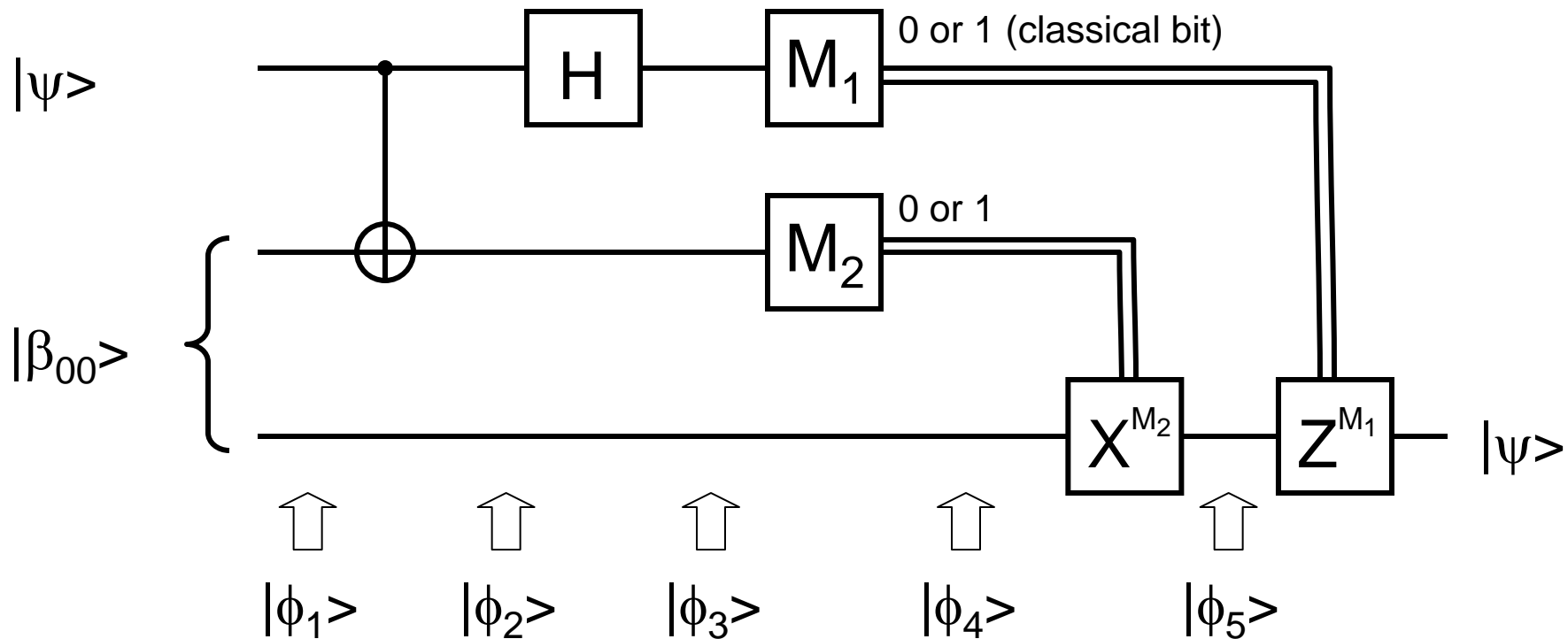

$$|\phi_3\rangle = 2^{-1}(c_0|000\rangle + c_0|100\rangle + c_0|011\rangle + c_0|111\rangle + c_1|010\rangle - c_1|110\rangle + c_1|001\rangle - c_1|101\rangle)$$

$M_1=1, M_2=0$:

$$|\phi_4\rangle = c_0|100\rangle - c_1|101\rangle = |10\rangle(c_0|0\rangle - c_1|1\rangle)$$

$$|\phi_4\rangle \xrightarrow{X^0=1} |\phi_5\rangle = |\phi_4\rangle \xrightarrow{Z^1=Z} |\psi\rangle = c_0|0\rangle + c_1|1\rangle$$

Teleportation – measurement results $M_1=0, M_2=1$

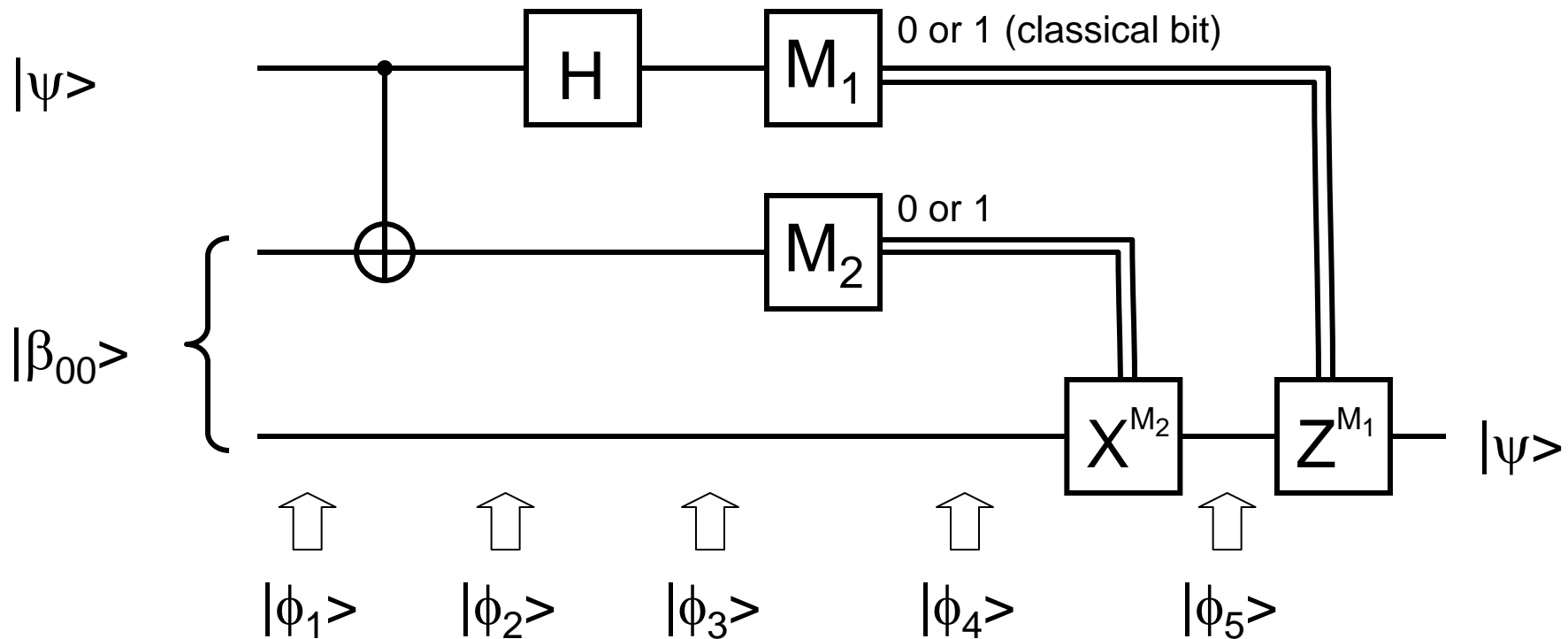

$$|\phi_3\rangle = 2^{-1}(c_0|000\rangle + c_0|100\rangle + c_0|011\rangle + c_0|111\rangle + c_1|010\rangle - c_1|110\rangle + c_1|001\rangle - c_1|101\rangle)$$

$$M_1=0, M_2=1:$$

$$|\phi_4\rangle = c_0|011\rangle + c_1|010\rangle = |01\rangle(c_0|1\rangle + c_1|0\rangle)$$

$$|\phi_4\rangle \xrightarrow{X^1=X} |\phi_5\rangle = c_0|0\rangle + c_1|1\rangle \xrightarrow{Z^0=1} |\psi\rangle = |\phi_5\rangle$$

Teleportation – measurement results $M_1=1, M_2=1$

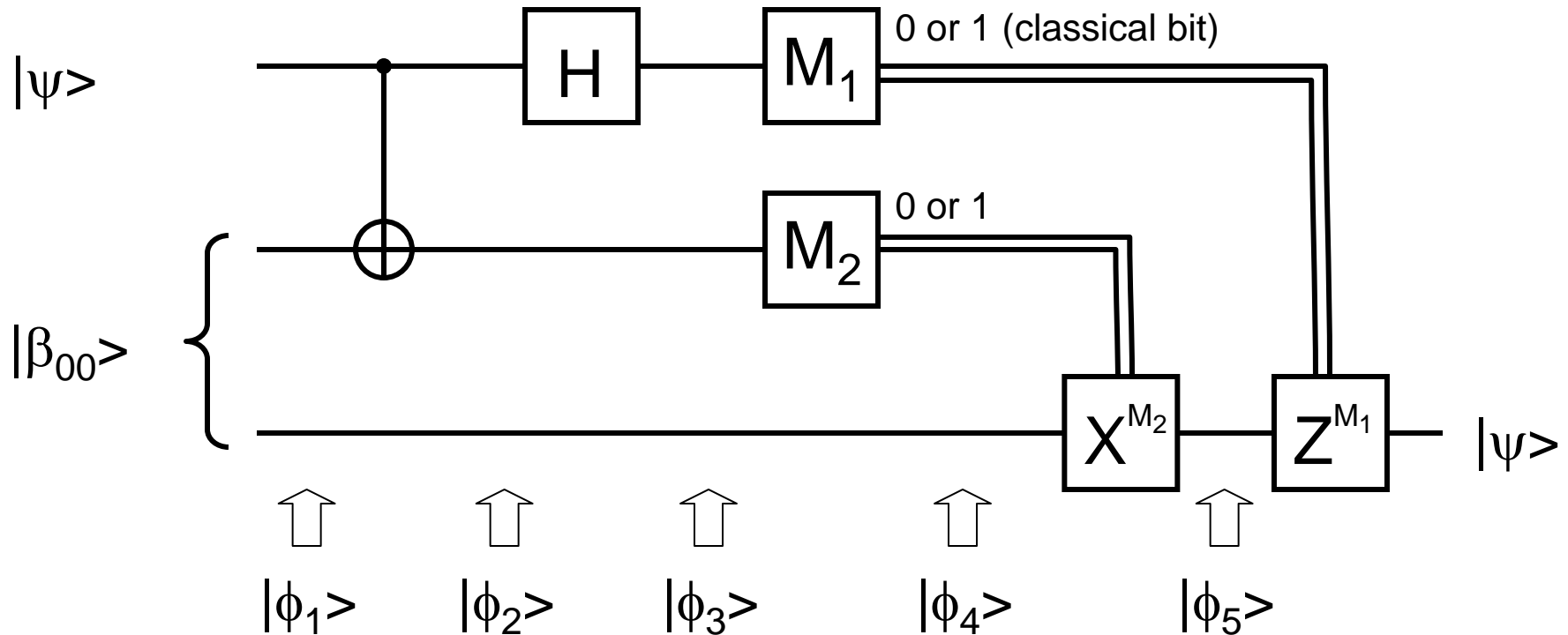

$$|\phi_3\rangle = 2^{-1}(c_0|000\rangle + c_0|100\rangle + c_0|011\rangle + c_0|111\rangle + c_1|010\rangle - c_1|110\rangle + c_1|001\rangle - c_1|101\rangle)$$

$$M_1=1, M_2=1:$$

$$|\phi_4\rangle = c_0|111\rangle - c_1|110\rangle = |11\rangle(c_0|1\rangle - c_1|0\rangle)$$

$$|\phi_4\rangle \xrightarrow{X^1=X} |\phi_5\rangle = c_0|0\rangle - c_1|1\rangle \xrightarrow{Z^1=Z} |\psi\rangle = c_0|0\rangle + c_1|1\rangle$$

...before



after ...



You better learn
how teleportation works!!!